

501-47

352410.0

DA - Monteringsvejledning (Side 2)

EN - Assembly instruction (Page 13)

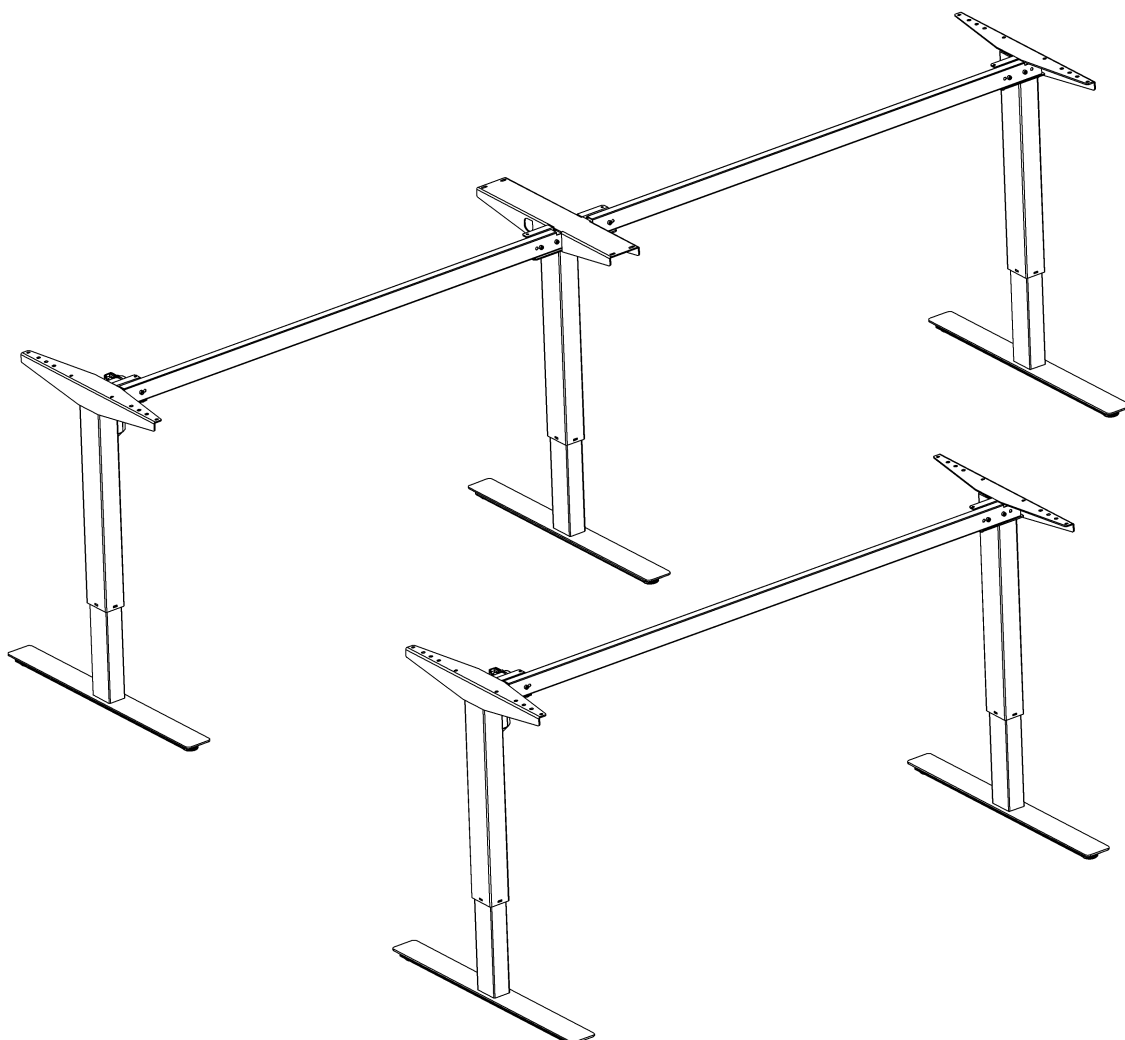

INDHOLDSFORTEGNELSE

1. Råd om sikkerhed og advarsler
2. Retningslinjer vedrørende anvendelse
3. Opstilling og installation
4. Betjening
5. Vedligeholdelse, rengøring og fejl
6. Teknisk data
7. Oversigt over dele
8. Monteringsvejledning
9. Overensstemmelseserklæring

VIGTIG INFORMATIONER!

De bør ABSOLUT læse denne brugsanvisning og montagevejledning før opstilling, installation og ibrugtagning. På den måde beskytter de Dem selv og Deres produkter.

1. Råd om sikkerhed og advarsler

Læs venligst brugsanvisningen, før border tages i brug for første gang. Den giver vigtig henvisninger om sikkerhed, anvendelse, installation og vedligeholdelse af border. på den måde beskytter De Dem selv om undgår skader på bordet.

Opbevar venligst denne brugsanvisning og giv den videre til en eventuel senere bruger!

2. Retningslinjer vedrørende anvendelse

Det elektriske, højde Justerbare bord er designet til brug i en tør inderdørs atmosfære (0-40 °C/ 0-140 °F; 20-90% relativ luftfugtighed). Bordets højde er trinløst justerbart, så det kan indstilles til den mest ergonomisk korrekte arbejdshøjde:

- Det er ikke designet til brug i andre tilfælde end beskrevet. F.eks. må de ikke anvendes undendørst, i områder med høj fugtighed/damp eller til at løfte personer med. Al anden anvendelse er på egen risiko!
- Man må ikke kravle, ligge eller i øvrigt bevæge sig rundt om bordet, og man må ikke sidde eller stå på bordet.
- Børn må kun anvende bordet under opsyn af voksne.
- Erstatningspligt - Producenten kan under ingen omstændigheder drages til ansvar for fejl eller skader, som opstår grundet fejlinstallation, uautoriseret indgreb eller forkert brug ud over det beskrevne i denne brugsanvisning.

3. Opstilling og installation

- Når bordet er monteret færdigt (se monteringsvejledningen) indstilles de justerbare fødder, så bordet står vandret og ikke vrider. Herefter sluttes bordet til netspændingen, og bordet er klar til brug.
- Sørg for at ingen ledninger kan komme i klemme.
- Placer bordet i tilstrækkelig afstand fra vindueskarmen, radiator, møbler og lign., så bordet kører fri af andre genstande.
- Placer ikke genstande under bordet, der er højere end 55 cm/21.
- Skal bordet flyttes efter det monteret og installeret, tages stikket ud af stikkontakten og bordpladen afmonteres. Bordet må IKKE løftes i bordpladen.

4. Betjening

OP/NED betjening.

Trykknop holdes inde samtidigt med at OP eller NED knap aktiveres.

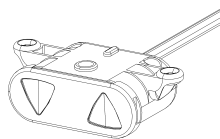

ADVARSEL: MANGLENDE OVERHOLDELSE AF MONTERINGS-, SIKKERHEDS- OG ANVENDELSES-INSTRUKTIONER VEDRØRENDE DETTE PRODUKT, KAN MEDFØRE ALVORLIGE PERSONSKADE.

5. Vedligeholdelse, rengøring og fejl

- Bordet kræver ikke vedligeholdelse ved anvendelse som beskrevet i K0apitel 2 i denne brugsanvisning.
- Rengøring må kun foretages med en klud opvredet i vand.
- Kontakt din leverandør, hvis der fremkommer mislyde

6. Teknisk data

Stel, materiale

Vægt	4 kg
Bredde	112 cm
Dybde	75 cm
Højde	68-118 cm
Maks. belastning	150 kg
Hastighed	25 mm/sec. ubelasted

Duty cycle

Betjening

Tilslutning

Standbyforbrug

7. Oversigt over dele

Se side 4.

8. Monteringsvejledning

Se side 5 - 12.

9. Overensstemmelseserklæring

Vi erklær herved på eget ansvar, at følgende produkter: 501-47

- Sidde og stå på bordene

som er omfattet af denne erklæring, er i overensstemmelse med følgende direktiver og andre normative dokumenter:

- Europa-Parlamentets og Rådets Direktiv 2006/42/EF af 17. Maj 2006 om maskiner og om ændringer af direktiv 95/16/EF

Med henvisning til overstående skal vi gøre opmærksom på, at:

- sidde og stå bordet betragtes som en maskine og
- sidde og stå bordet først må tages i brug, når det er monteret og installeret i overensstemmelse med forskrifterne i denne brugsanvisning/monteringsvejledning.

Manufacturer

ConSet A/S | Industrivej 23 | 6900 Skjern | Danmark

www.conset.com | Tlf.: +45 96800080 | conset@conset.com1

7. Oversigt over dele

Ⓐ Slave leg

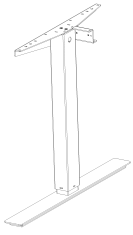

x1

Ⓑ Motor leg

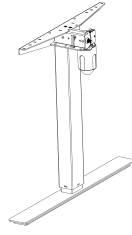

x1

Ⓒ Adjustable glide

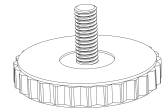

x4

Ⓓ Travers

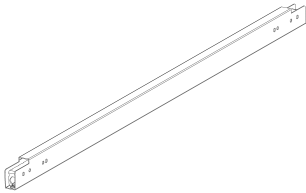

x1

Ⓔ Carrier tube

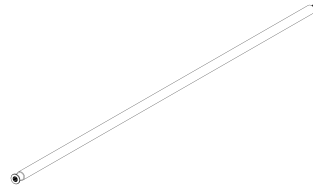

x1

Ⓕ Screw M6x35

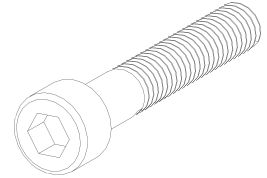

x4

Ⓖ Screw M6x12

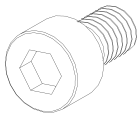

x4

Ⓗ Tabletop bracket

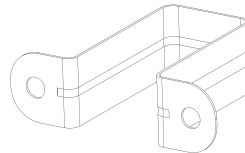

x1

Ⓘ Kontrolpanel

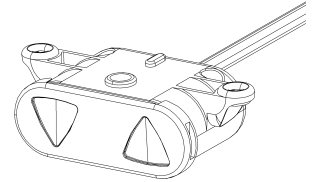

x1

Ⓙ Strømforsyning

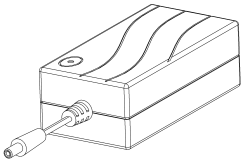

x1

Ⓚ Power supply bracket

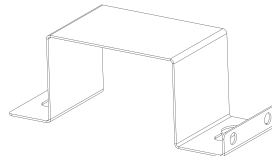

x1

Ⓛ Strømkabel

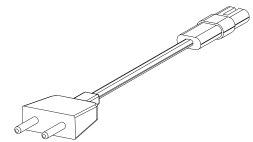

x1

Ⓜ Cable tie



x2

Ⓝ Lednings søm

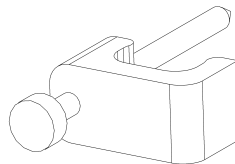

x4

Ⓞ Træskue 5x16mm

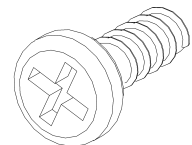

x14

8. Monteringsvejledning

1 Leg mounting

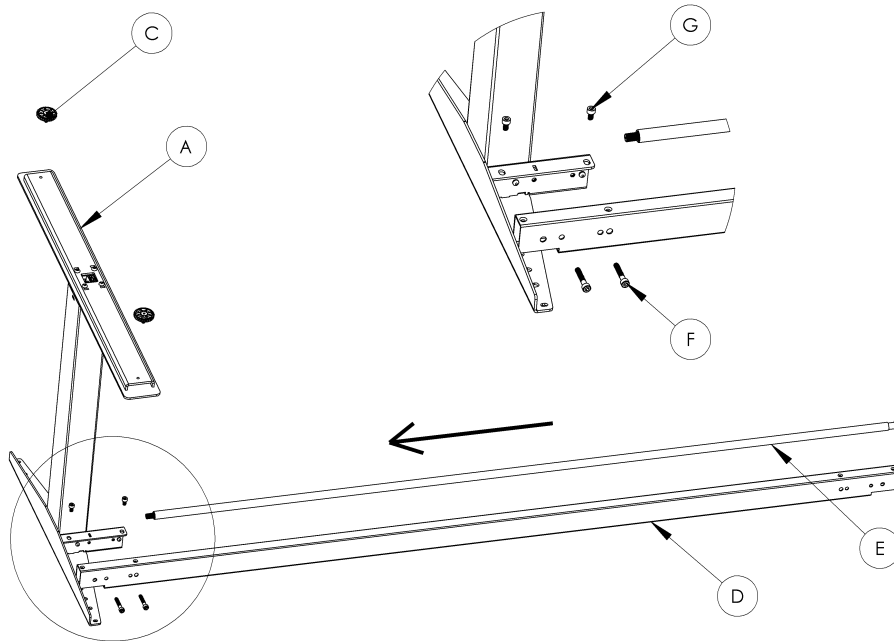

2 Leg mounting

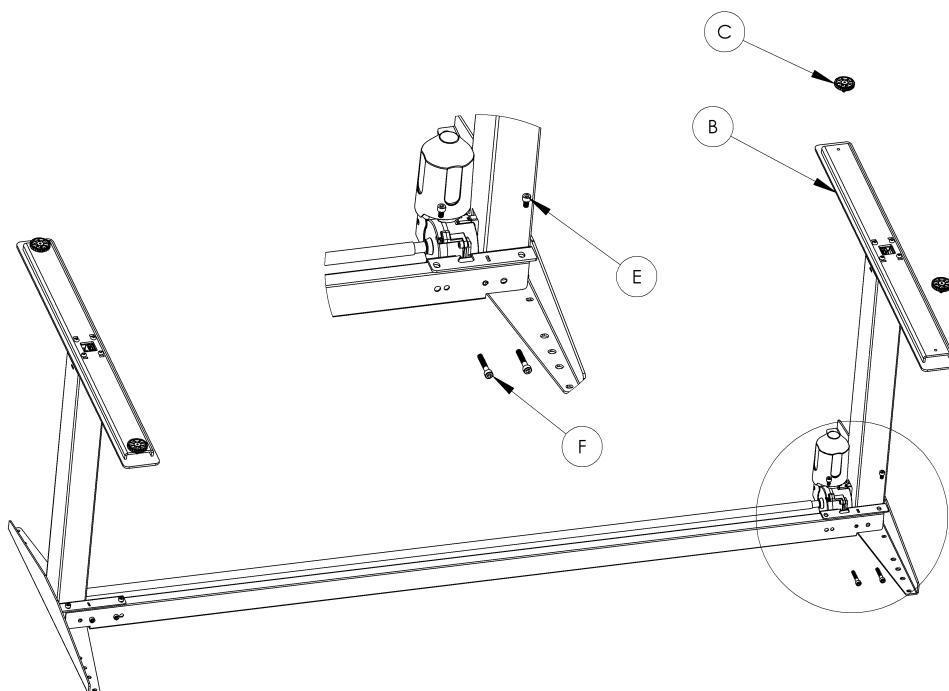

5 Ledninger

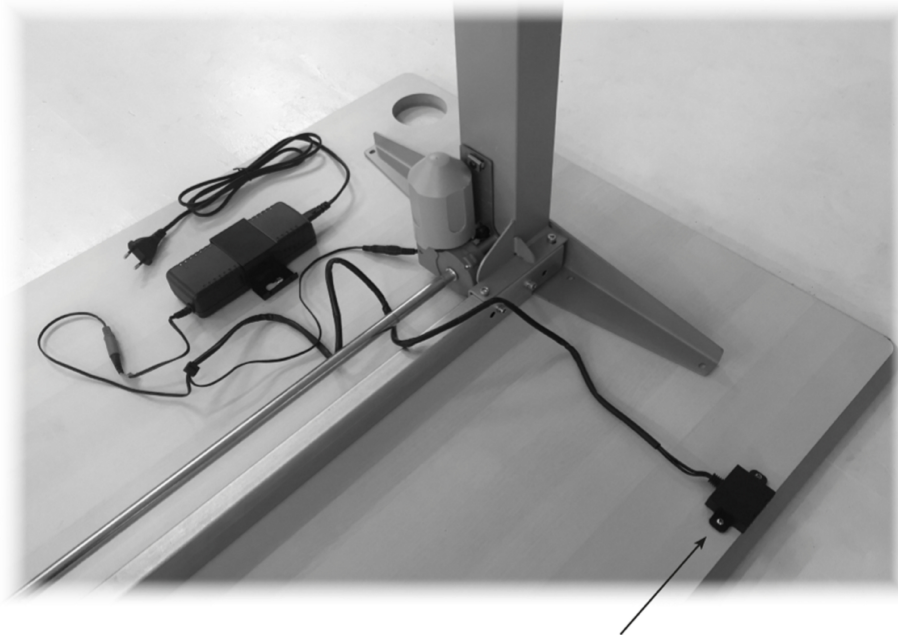

SKRUERNE MÅ IKKE SPÆNDES FOR HÅRDT, IDET DET KAN SKADE BETJENINGEN AF BORDET

DO NOT OVER TIGHTEN THE SCREWS SINCE THIS MAY HARM THE FUNCTION OF THE CONTROL

ZIEHEN SIE DIE SCHRAUBEN NICHT ZU FEST AN DA DIES DIE FUNKTION BEEINTRÄCHTIGEN KANN DER STEUERUNG

6 Ledninger

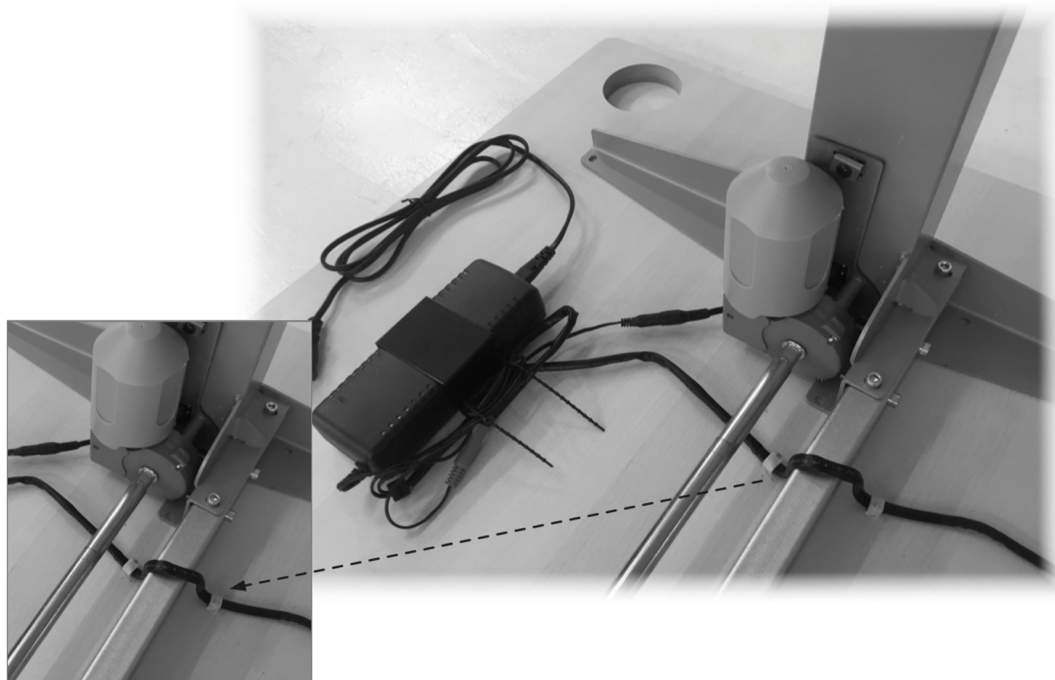

7.1. Monteringsvejledning

(A) Slave leg

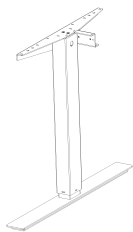

x1

(B) Motor leg

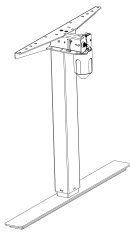

x1

(C) Center leg

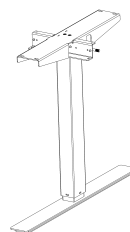

x1

(D) Adjustable glide

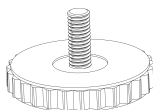

x6

(E) Travers

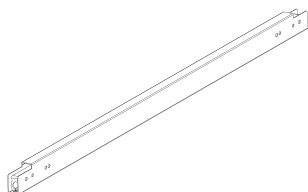

x2

(F) Carrier tube

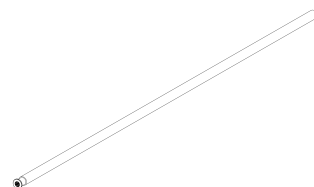

x2

(G) Screw M6x35

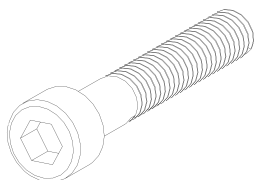

x8

(H) Screw M6x12

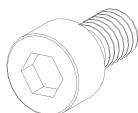

x8

(I) Tabletop bracket

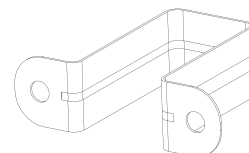

x2

(J) Kontrolpanel

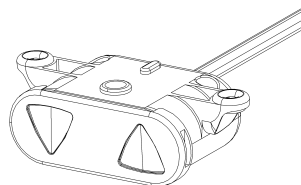

x1

(K) Strømforsyning

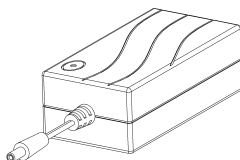

x1

(L) Power supply bracket

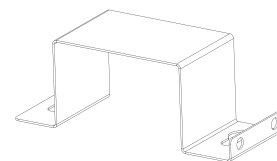

x1

(M) Strømkabel

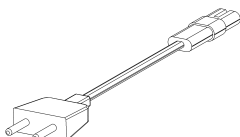

x1

(N) Cable tie



x2

(O) Lednings søm

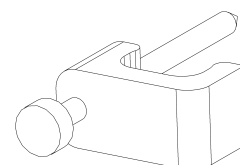

x4

(P) Træskue 5x16mm

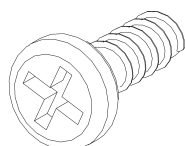

x20

8.1. Monteringsvejledning

1 Leg mounting

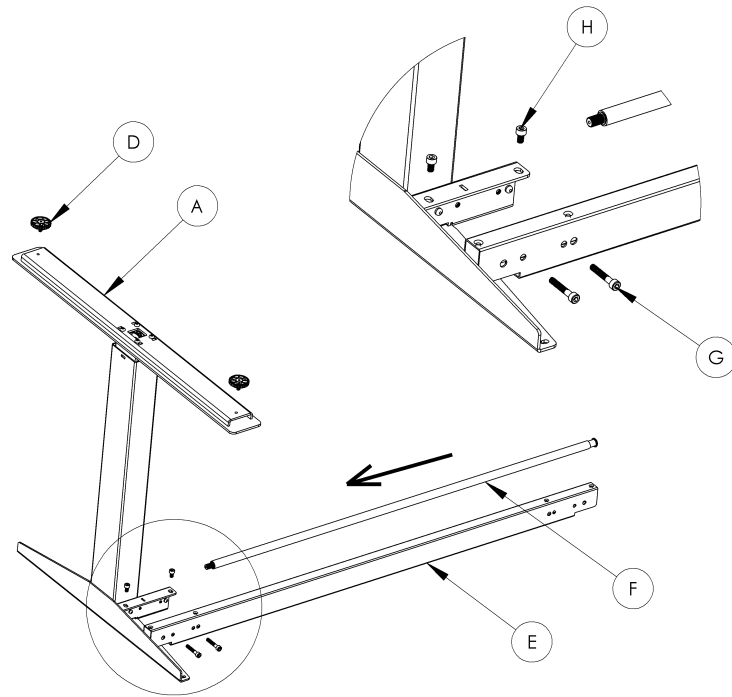

2 Leg mounting

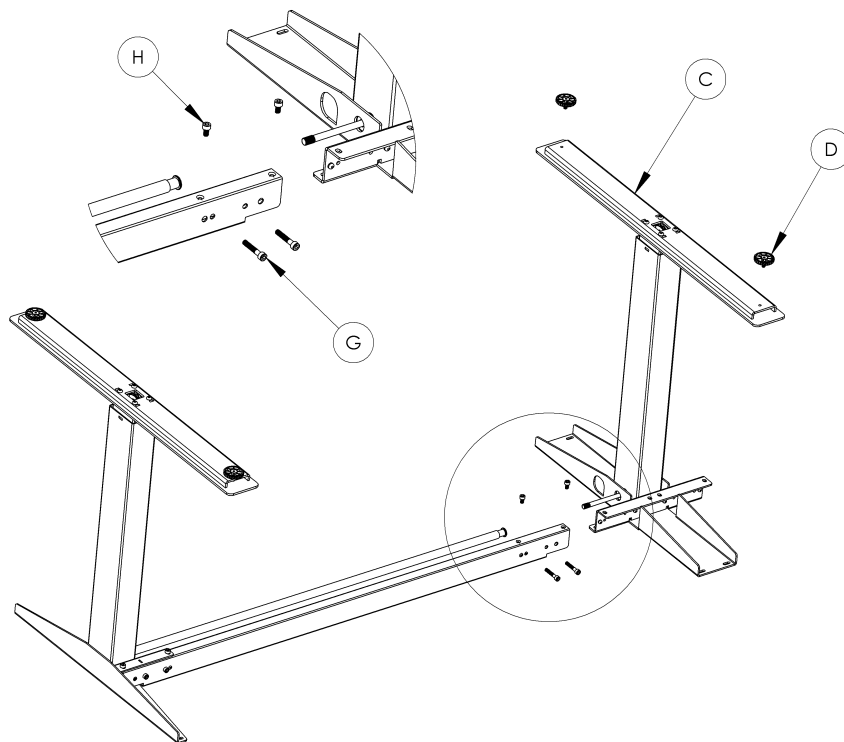

3 Leg mounting

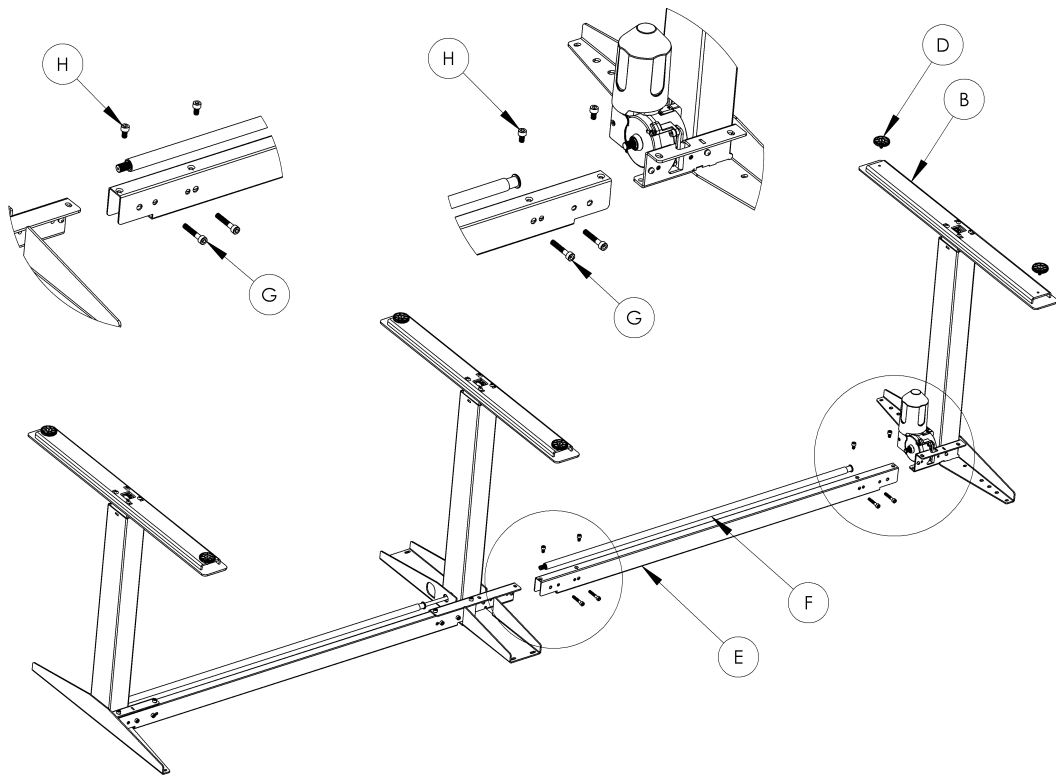

4 Tabletop mounting

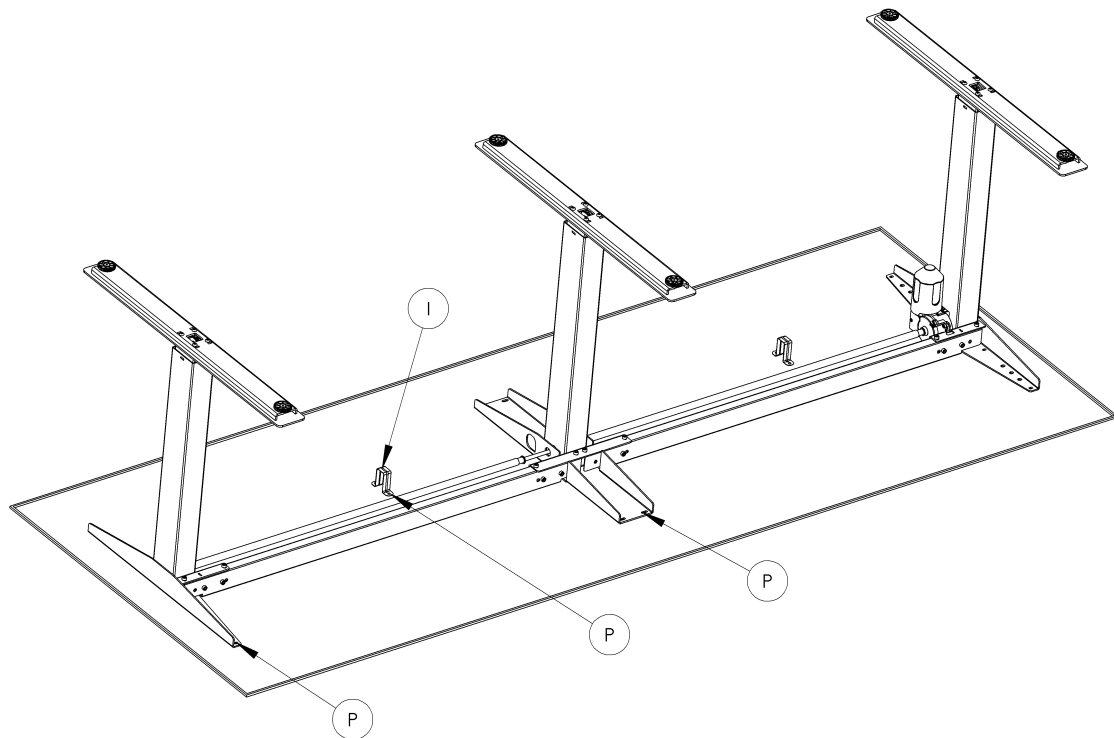

5 Power and control mounting

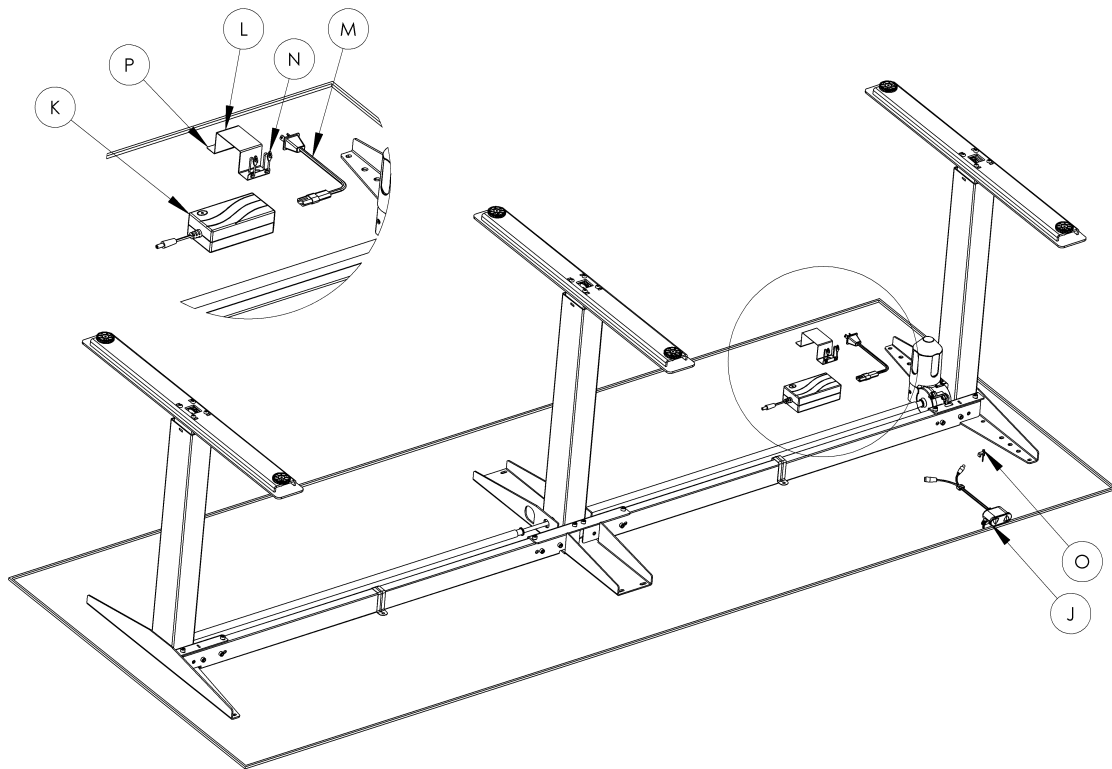

6 Ledninger

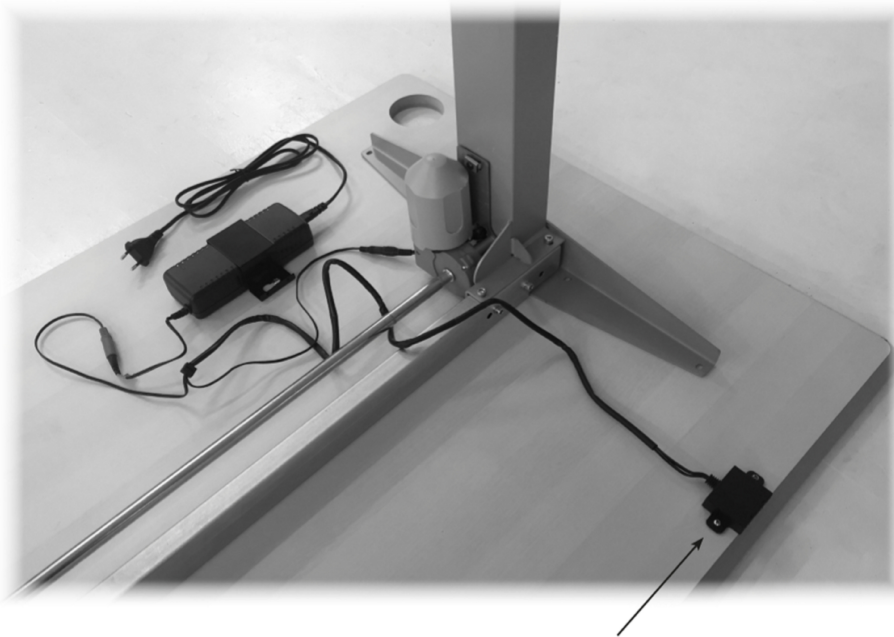

SKRUENE MÅ IKKE SPÆNDES FOR HÅRDT, IDET DET KAN SKADE BETJENINGEN AF BORDET

DO NOT OVER TIGHTEN THE SCREWS SINCE THIS MAY HARM THE FUNCTION OF THE CONTROL

ZIEHEN SIE DIE SCHRAUBEN NICHT ZU FEST AN DA DIES DIE FUNKTION BEEINTRÄCHTIGEN KANN DER STEUERUNG

7 Ledninger

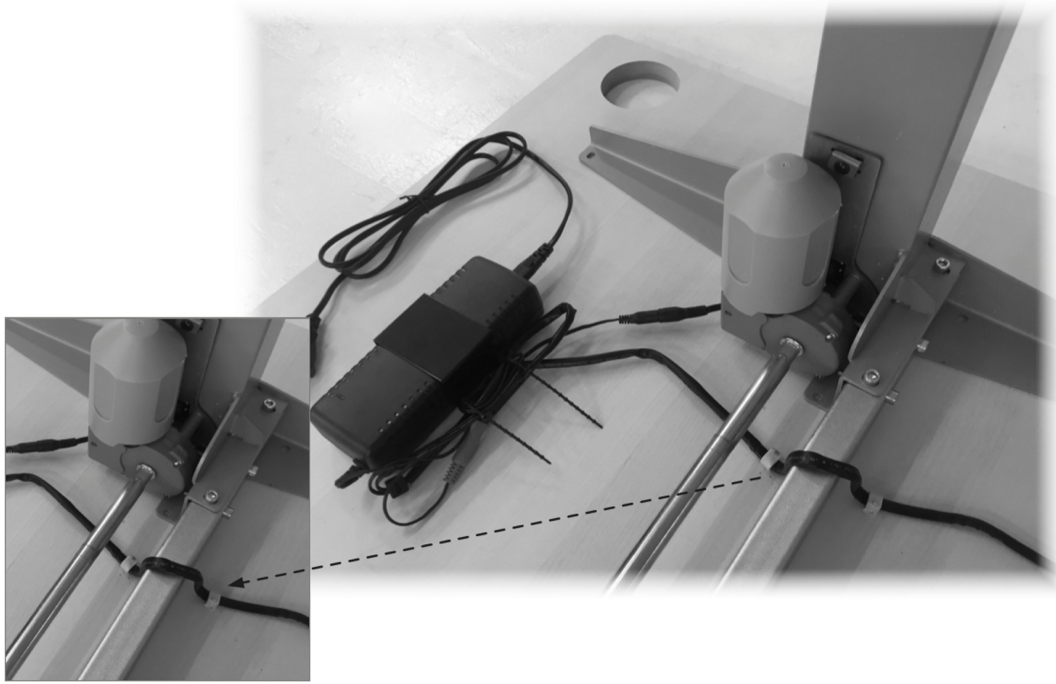

TABLE OF CONTENTS

1. Safety and warnings
2. Usage
3. Set up and installation
4. Operation
5. Maintenance and defects
6. Technical data
7. Parts
8. Assembly instructions
9. Declaration of conformity

IMPORTANT NOTES!

Prior to installment, use and maintenance of the table frame, any installer and any user of the table must study this assembly and operation manual carefully, so as to gain a complete understanding of its contents

1. Safety and warnings

This table complies with the prescribed safety regulations. Inappropriate use may cause damage to persons and table.

Please read the operation manual prior to start using the table. It provides you with important information about safety, use, installation and maintenance of the table, and thus protecting you and your children and avoiding damage on the table.

Please guard this operation manual and pass it on to any future owner!

2. Usage

The electromotive, height-adjustable tables are designed for workstations in dry work environments only (0-40°C; 20-90% relative humidity). The table height is infinitely adjustable, so that it can be set to the most ergonomically suitable working level:

- They have not been designed for other purposes than those included in this manual, e.g. they are not to be used in areas of high humidity or dampness, nor for lifting people. Any other use is at one's own risk!
- Do not crawl, lie or move around under the table frame, and do not sit or stand on the table frame.
- CHILDREN should only use the table when supervised by adults.
- Liability - The manufacturer accepts under no circumstances warranty claims or liability claims for damages arising from improper use or handling of the table frame other than that described in this operation manual.

3. Set up and installation

- When the table has been assembled (see assembly instructions in CHAPTER 8) the adjustable feet are installed so that the table is level and does not shift. Then the table is connected to the 100-240 VAC outlet and the table is ready for use.
- Make sure that no cables can get jammed.
- Place the table in a safe distance from window frames, radiators, furniture etc. so that people do not get stuck.
- Do not place any objects above 21" (55 cm) underneath the table.
- When moving the table after it has been assembled, the tabletop needs to be removed. The table CANNOT be lifted by the tabletop. The desk need to be lowered to minimum height before moving.

4. Operation

UP/DOWN operation:

Push the buttons for operation up or down

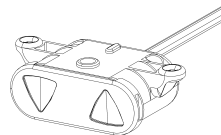

WARNING: FAILURE TO COMPLY WITH OR OBSERVE ALL ASSEMBLY, SAFETY AND OPERATION INSTRUCTIONS AND WARNINGS REGARDING THE USE OF THIS PRODUCT MAY RESULT IN SERIOUS BODILY INJURY.

5. Maintenance and defects

- The table does not require any maintenance by usage as described in chapter 2 in the directions for use.
- The table is only to be maintained with a damp cloth
- In the event of the occurrence of jarring sounds during operation, STOP using the table and please contact the dealer.

6. Technical data

Frame, materials

Weight	4 kg
Width	112 cm
Depth	75 cm
Height	68-118 cm
Max. load	150 kg
Speed	25 mm/sec. unloaded

Duty cycle

Operation

Voltage

Standby Consumption

7. Parts

See page 16.

8. Assembly instructions

See page 16 - 23.

9. Declaration of conformity

We hereby declare, under our sole responsibility that the following products:

- Sit and stand table product type 501-47

is in accordance with:

- Directive 2006/42/EF of The European Parliament and of the Council of 17 May 2006 on machinery

With reference to the above please be aware that:

- the sit and stand table is considered a machine and
- the sit and stand table may not be used until it has been assembled and installed according to the instructions.

Manufacturer

ConSet A/S | Industrivej 23 | 6900 Skjern | Denmark
www.conset.com | Tlf.: +45 96800080 | conset@conset.com

7. Parts

(A) Slave leg

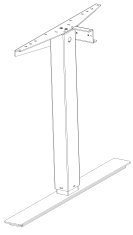

x1

(B) Motor leg

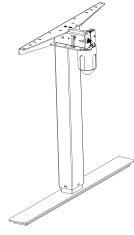

x1

(C) Adjustable glide

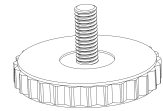

x4

(D) Travers

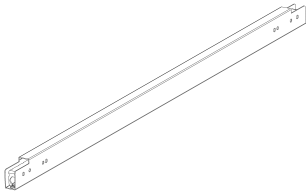

x1

(E) Carrier tube

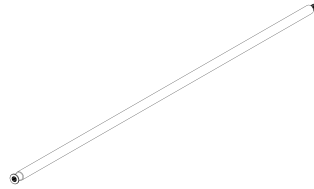

x1

(F) Screw M6x35

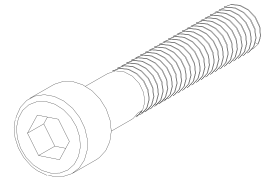

x4

(G) Screw M6x12

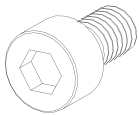

x4

(H) Tabletop bracket

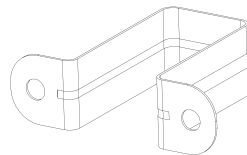

x1

(I) Control panel

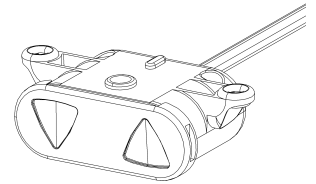

x1

(J) Power supply

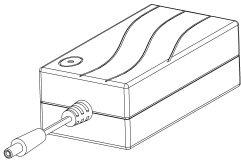

x1

(K) Power supply bracket

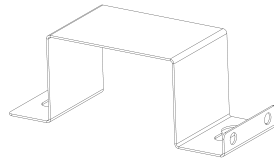

x1

(L) Power cord

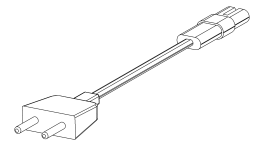

x1

(M) Cable tie



x2

(N) Wirenail

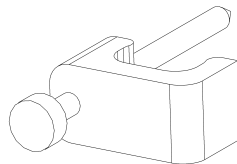

x4

(O) Wooden screw 5x16mm

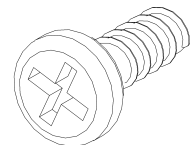

x14

8. Assembly instruction

1 Leg mounting

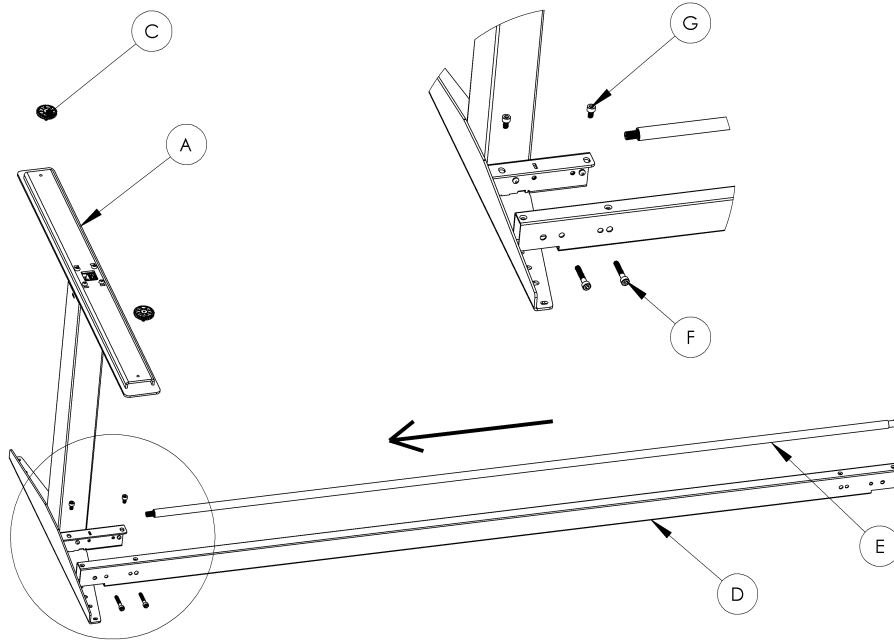

2 Leg mounting

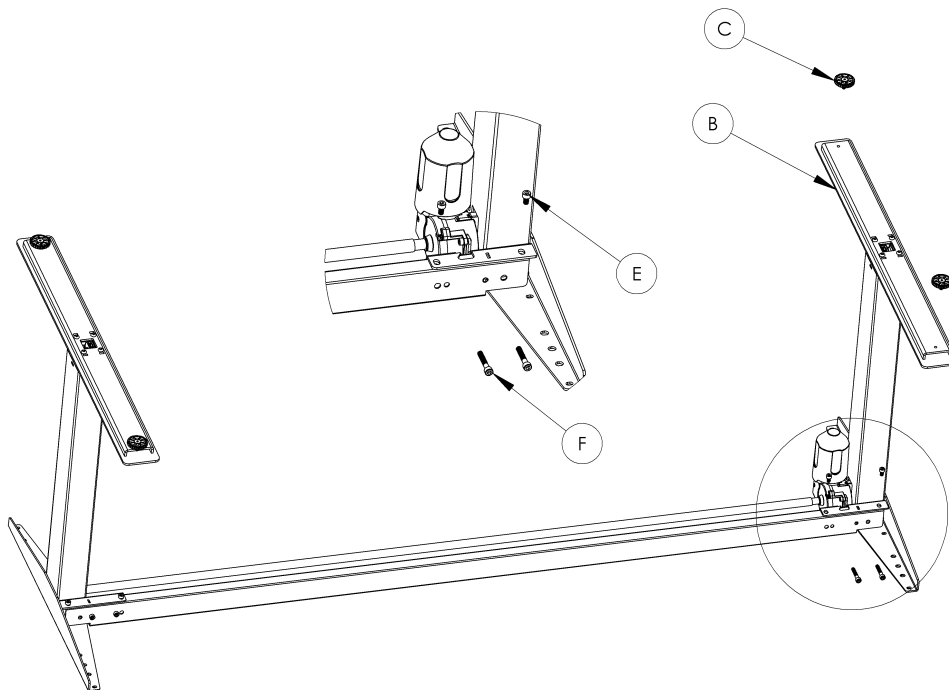

3 Tabletop mounting

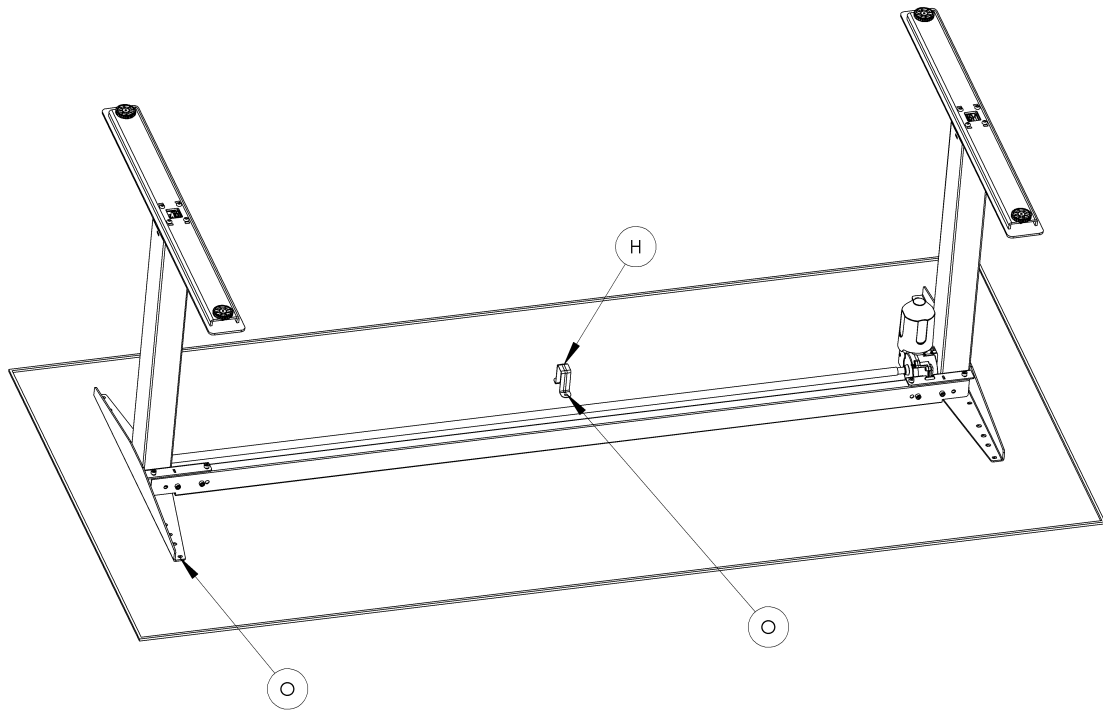

4 Power and control mounting

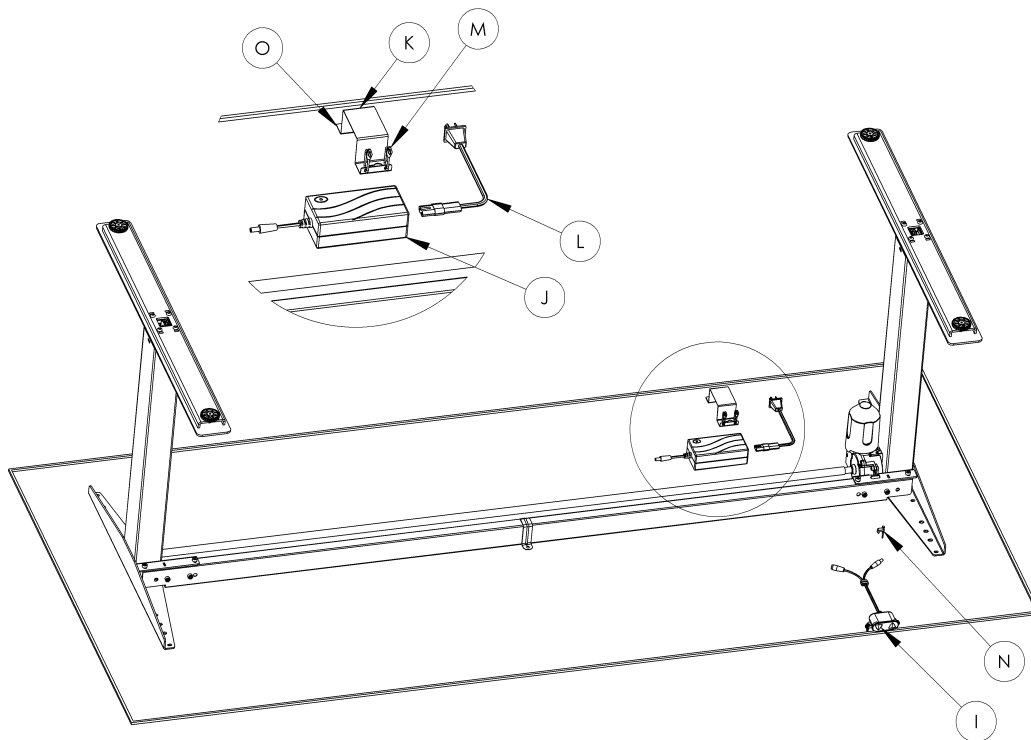

5 Wiring

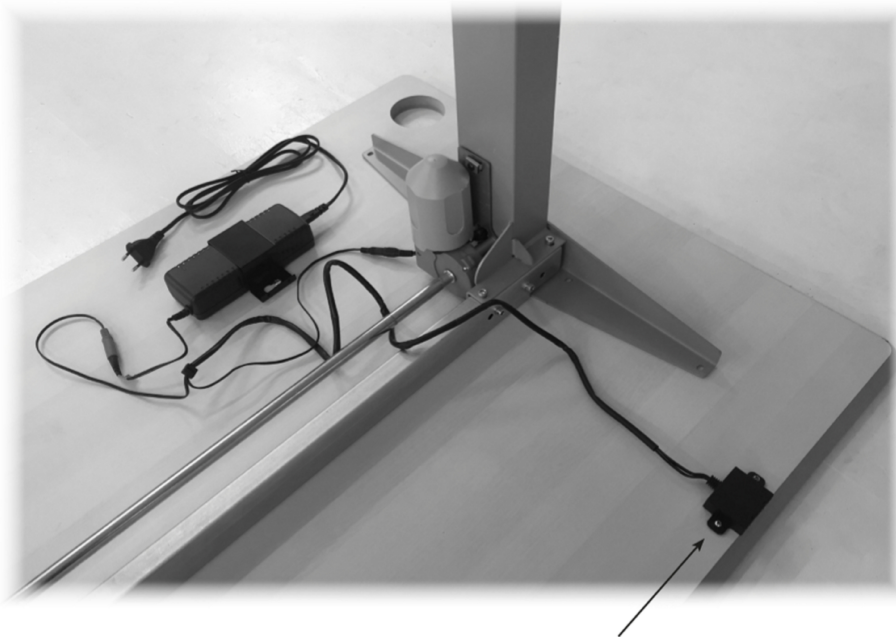

SKRUERNE MÅ IKKE SPÆNDES FOR HÅRDT, IDET DET KAN SKADE BETJENINGEN AF BORDET

DO NOT OVER TIGHTEN THE SCREWS SINCE THIS MAY HARM THE FUNCTION OF THE CONTROL

ZIEHEN SIE DIE SCHRAUBEN NICHT ZU FEST AN DA DIES DIE FUNKTION BEEINTRÄCHTIGEN KANN DER STEUERUNG

6 Wiring

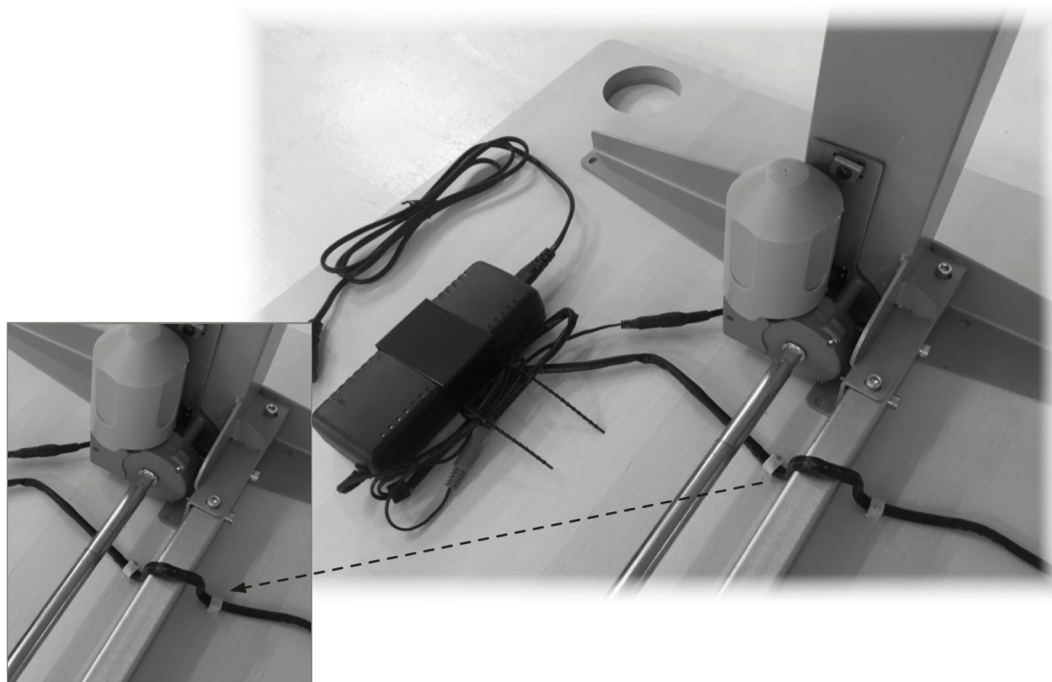

7.1. Assembly instruction

Ⓐ Slave leg

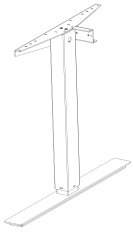

x1

Ⓑ Motor leg

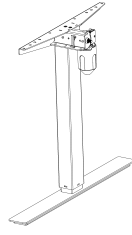

x1

Ⓒ Center leg

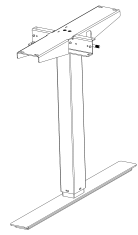

x1

Ⓓ Adjustable glide

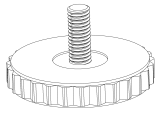

x6

Ⓔ Travers

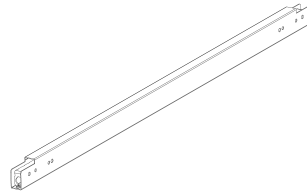

x2

Ⓕ Carrier tube

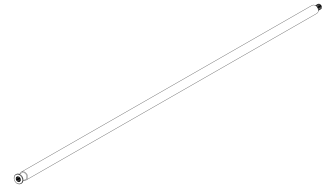

x2

Ⓖ Screw M6x35

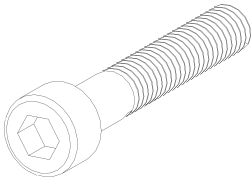

x8

Ⓗ Screw M6x12

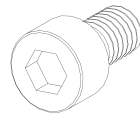

x8

Ⓘ Tabletop bracket

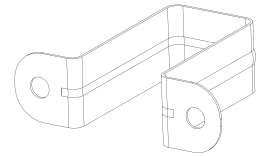

x2

Ⓙ Control panel

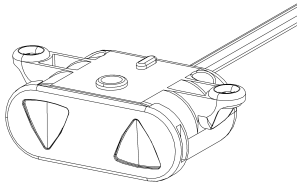

x1

Ⓚ Power supply

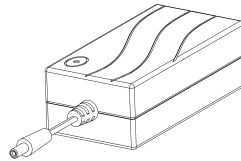

x1

Ⓛ Power supply bracket

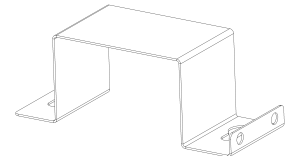

x1

Ⓜ Power cord

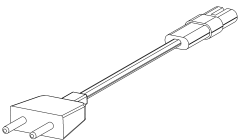

x1

Ⓝ Cable tie



x2

Ⓞ Wirenail

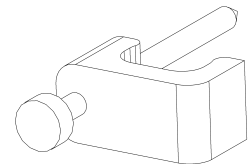

x4

Ⓟ Wooden screw 5x16mm

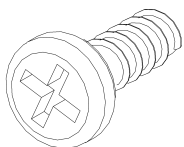

x20

8.1. Assembly instruction

1 Leg mounting

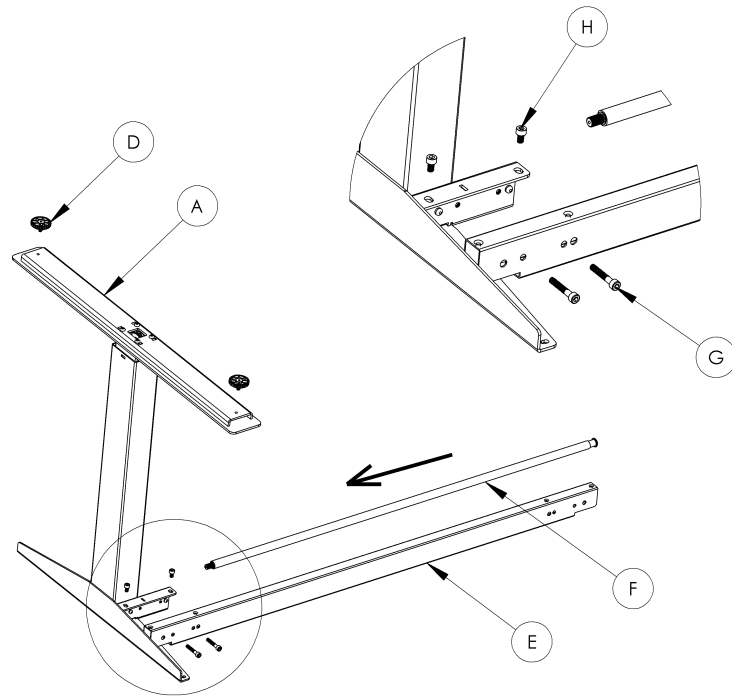

2 Leg mounting

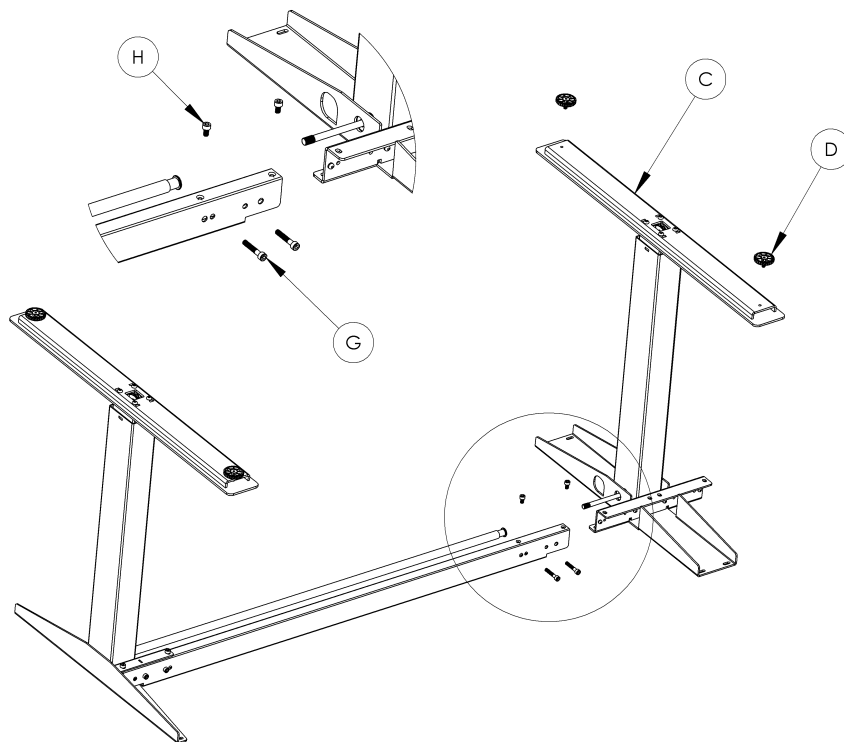

3 Leg mounting

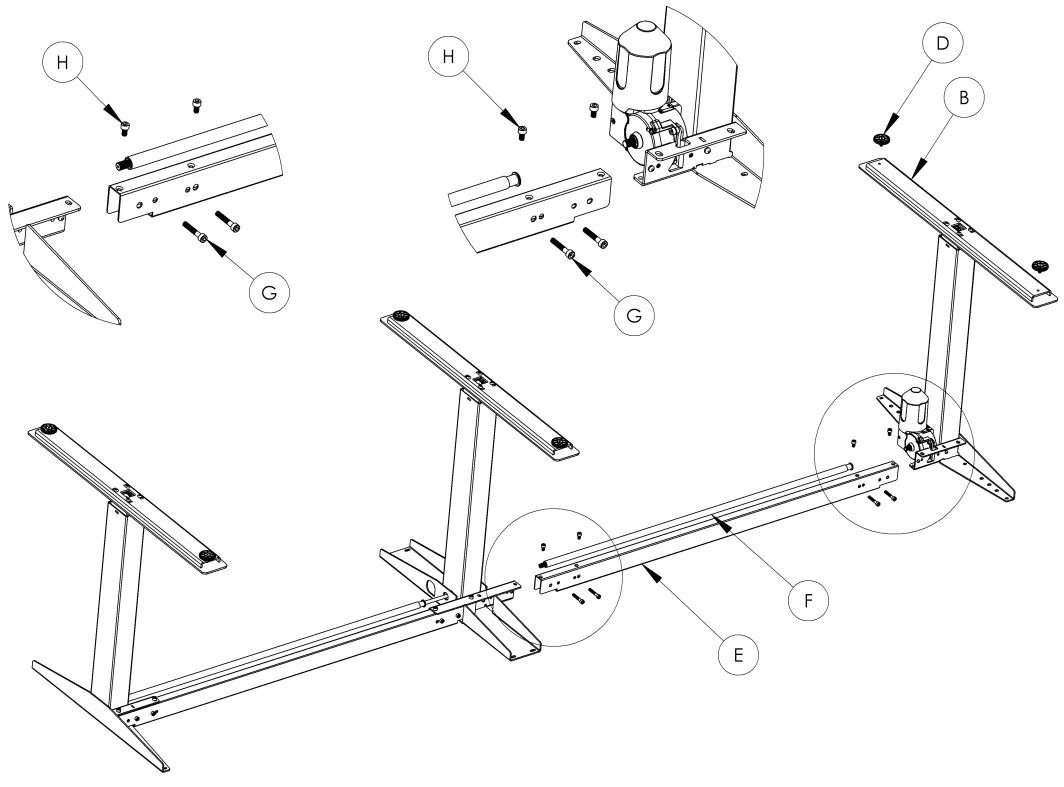

4 Tabletop mounting

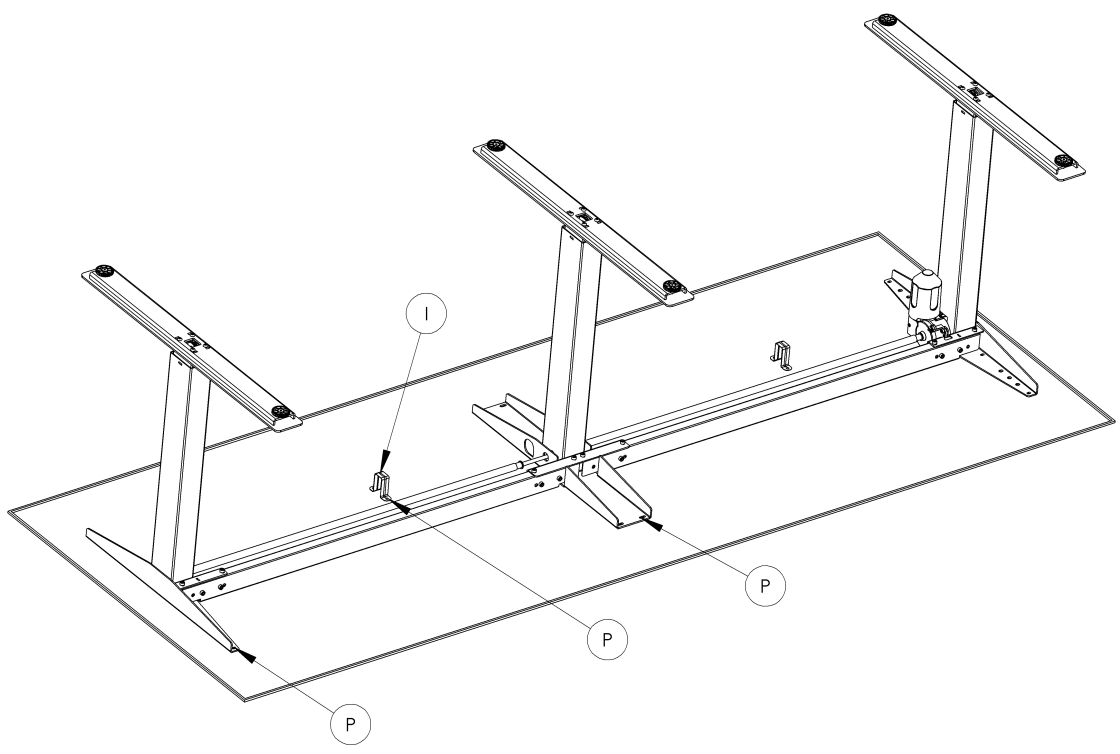

5 Power and control mounting

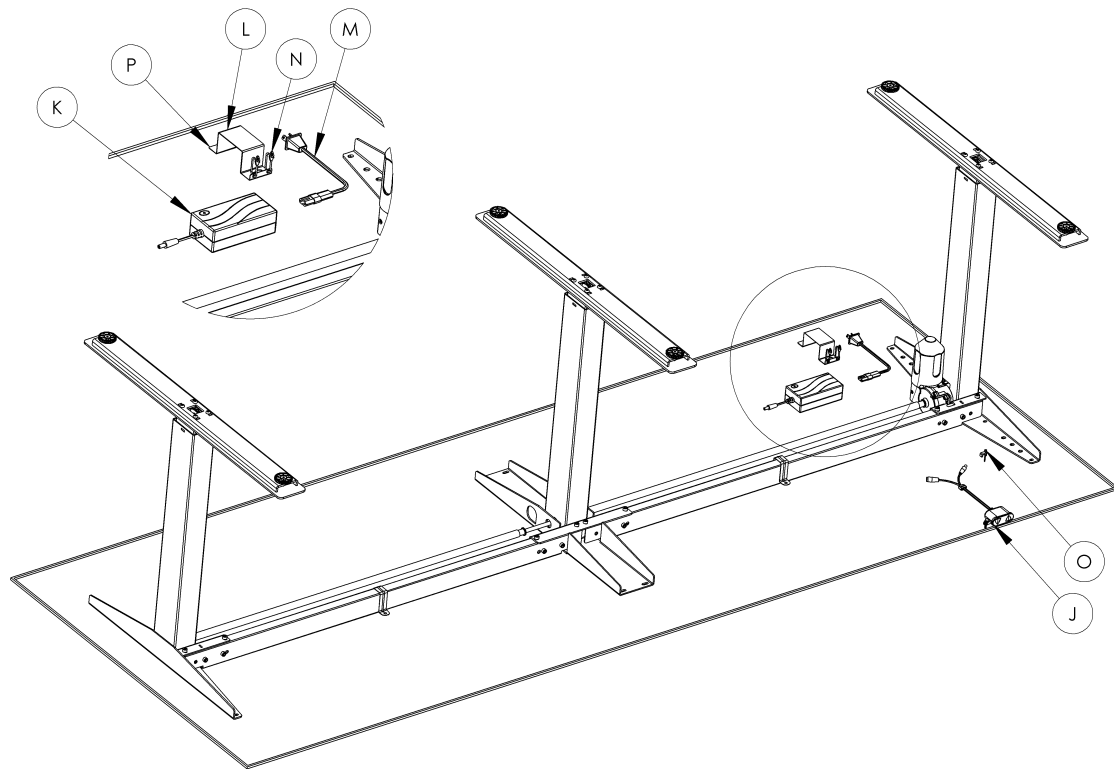

6 Wiring

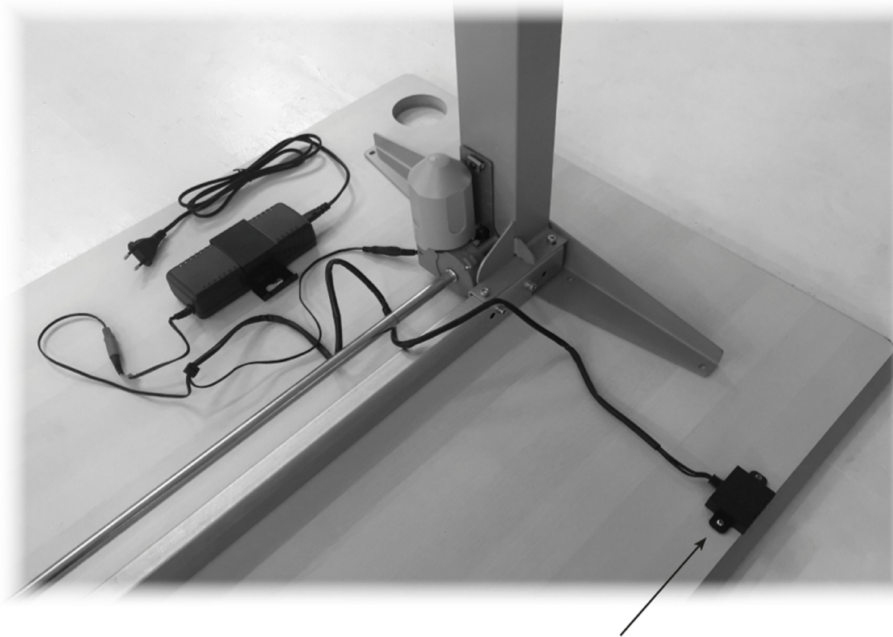

SKRUENE MÅ IKKE SPÆNDES FOR HÅRDT, IDET DET KAN SKADE BETJENINGEN AF BORDET

DO NOT OVER TIGHTEN THE SCREWS SINCE THIS MAY HARM THE FUNCTION OF THE CONTROL

ZIEHEN SIE DIE SCHRAUBEN NICHT ZU FEST AN DA DIES DIE FUNKTION BEEINTRÄCHTIGEN KANN DER STEUERUNG

7 Wiring

